

INTEGRATABLE SYSTEMS

MC2000 U (100x17)

Super Fast



Small-sized model specially designed for its integration into production lines.

High marking speed on all kinds of materials up to 62 HRC hardness.

Reliable, strong and low-maintenance machine.

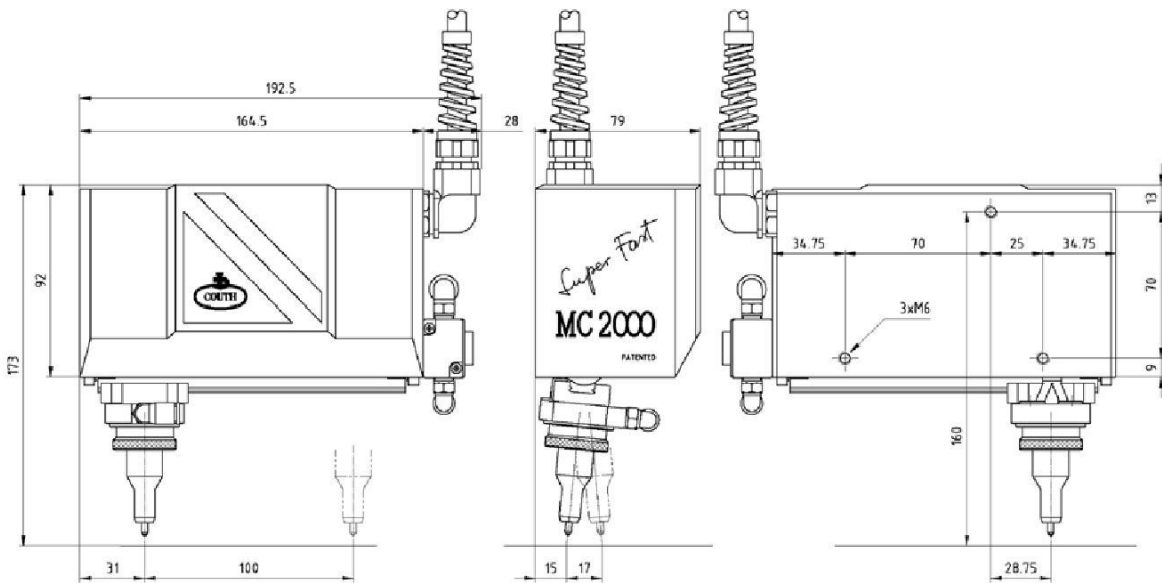

Technical Features

- Marking area 100x17mm (100x25mm option available).
- Maximum marking speed: 12 char./sec.
- Choice of marking heads: N7, N10, N14 or N20 (pneumatic drive) and S6 (electric drive) depending on marking requirements.
- Robotics cable length: 2 metres (custom length possible).
- Air pressure: 6 bars.
- Connection to T2 controller (see controller specifications).
- Wide range of characters from 1 to 48 mm. Anagrams, logos, etc.
- PC-based editing software.



Thailand Distributor
CODE MASTER CO.,LTD.
66 2nd Fl., Soi Ram Intra 99, Kannayao Sub-District, Kannayao District, Bangkok 10230
Tel. (02) 540-1061-62, 089-133-5300 Fax. (02) 540-1869
Email : cmaster@truemail.co.th ; codemastercenter@gmail.com www.codemasternet.com



MC 2000T² CONTROLLER

MC 2000T² is the latest generation electronic controller for all MC2000 marking machines. The MC 2000T² controller embodies the best features of all previous COUTH control units and incorporates cutting-edge technology improvements. That makes it the most powerful and flexible tool of its kind in the market.

Its new vectorial-definition based marking system makes it possible to mark any kind and size of character and logo without losing resolution.

Technical Features

- Stand-alone unit. No PC required for its operation.
- Controller suitable for any COUTH marking system.
- Pneumatic or electromagnetic drive according to mechanics.
- Graphic menus for easier use.
- Multi-language menus.
- Vectorial marking without losing resolution whatever the size.
- Straight, oblique, arc and symmetrical marking capabilities.
- Marking of serial numbers, prior setting of range and recurrence, shifts, time, date, week...
- Marking of logos and special characters.
- Marking of 2D DataMatrix coding.
- Choice of fonts. Possibility of creating customised fonts.
- Adjustable character compression, expansion, spacing, italic writing and dot density.
- Adjustable speed and impacting force.
- Plug-in or built-in Start/Stop push-button box.
- Slave mode of operation with PC or PLC.
- RS232 series interface, adaptable to RS485, Ethernet, Profibus...
- 11 input signals and 7 output signals, all programmable for connection to PLC.
- Socket for external keyboard connection.
- Socket for barcode or DataMatrix code reader connection.
- Connector for plate feeder, rotating devices, jogging systems...
- 40-line files (75 characters/line)
- Storage of up to 500 files
- PC-compatible SD Card for storage and transfer of settings, files, logos...
- RoHS standard compliant SMD technology. - Complies with CE mark European Directive.
- Power supply: 110/220V, 50/60Hz.
- 120mmx90mm, 320x240 pixel grey scale display.
- Dimensions (width x height x depth -mm-) 280x160x261.
- Weight: 5.450kg



Zikuñaga 48 - Apdo. 30, 20120 HERNANI - SPAIN
 Tfno.: +34 943 556 412 Fax: +34 943 555 262
 E-mail: couth@couth.com
www.couth.com



ISO 9001:2008